

Airflow 1™

COMBI 310ml

A single component pneumatic bead applicator for cartridges and sachets

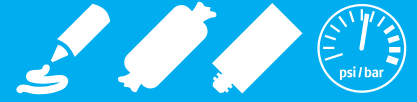

Piston driven rod action and separate front barrel enables both cartridges and sachets to be dispensed

Integral pressure regulator to control sealant flow

Sachet Plunger

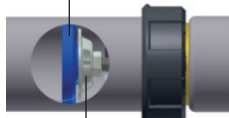

Cartridge Plunger

Rod Driven Cartridge/Sachet Plungers

Minimum trigger pressure for effortless use

PRODUCT FEATURES:

- 20% more power than Airflow 1 cartridge for higher viscose materials
- High volume trigger valve for immediate sealant flow
- Quick exhaust valve to minimise "flow-on"
- Manufactured in UK to high quality standards for reliability and safety
- Wide range of accessories and spare available to make the most of the applicator and give it a long service life
- 6.8bar (100psi) regulator as standard (others available).

Standard: 6.8 bar (100 psi) ●

Options available: 3.4 bar (50 psi) ●
5.2 bar (75 psi) ●
8.5 bar (125 psi) ○

The Cox Airflow 1 is part of a range of pneumatic applicators. Ideally suited to larger scale production line and commercial operations where easy access to compressed air is available, giving substantial productivity gains over manual applicators. The Airflow range provides fast, effortless application and smooth consistent sealant flow for high quality workmanship.

For more information call +44(0)1635 264500
Or visit www.pccox.co.uk

Airflow 1™

COMBI 310ml

A single component pneumatic bead applicator for cartridges and sachets

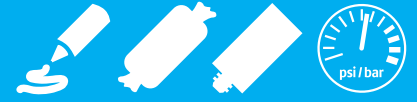

APPLICATIONS:

- For low to medium viscosity
- Cartridge: 1-component
- Cartridge volumes: 310ml
- Sachet volumes: 310ml

SPECIFICATIONS:

- Max Pneumatic Pressure: 6.8bar (100psi) (others available)
- Maximum Thrust: 1.34 kN (with 6.8 bar regulator)
- Barrel Length: 236mm
- Tool Weight: 1.30kg
- Tool Material: Black cast aluminium with epoxy coating handle, silver anodised aluminium barrel
- Certificates: ISO, REACH, CE, EN
- Packaging Options: 1 or 10 per box

WEB LINKS:

- **Academy video**
www.pccox.co.uk/en/cox-academy
- **Spare parts diagram**
www.pccox.co.uk/en/exploded-diagrams

OTHER MODELS AVAILABLE:

- Airflow 1 Cartridge
- Airflow 1 Sachet
- Airflow 1 Combi HP
- Airflow 1 1000 S
- Airflow 1 1000 L
- Airflow 1 BULK
- See also: Airflow 2 range or Airflow 3 range

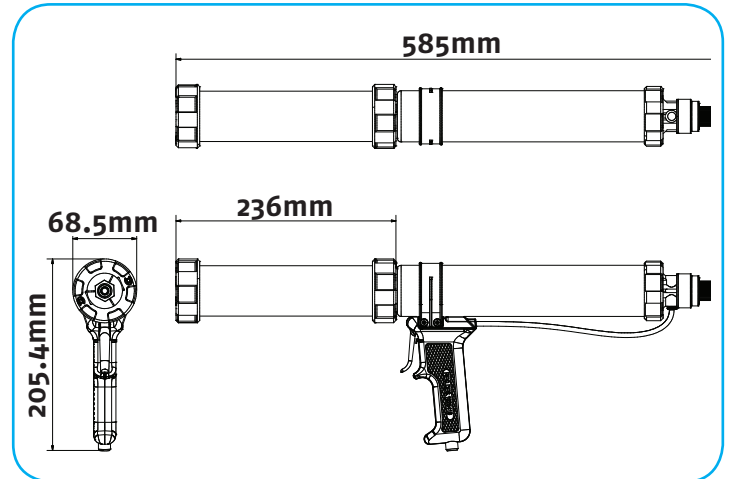

CARTRIDGES/SACHETS:

310ml:

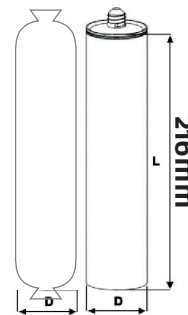

50mm 51mm

COMPRESSOR GUIDE

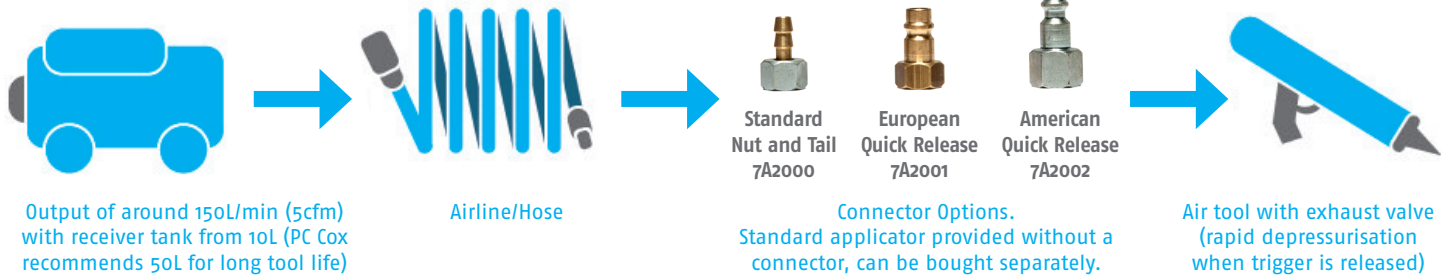

PC Cox Ltd., Turnpike Road, Newbury, Berkshire, RG14 2LR
 T Sales +44 (0) 1635 264500 F +44 (0) 1635 264555
 E sales@pccox.co.uk
www.pccox.co.uk



The original

©PC Cox Ltd. 2016 Cox is a trademark of PC Cox Ltd. Every effort has been made to ensure that the information contained in this leaflet was correct at the time of going to press. However, the company retains the right to change any specification without notice, in line with the company's policy of continual product development.
 1P3309

